

TOP CLASS “DOMINO III”

Stand alone sinewave inverter

TC05/12 and TC07/24

Instructions for installation and operation



A product of:

Advanced Solar Products AG
CH-8637 Laupen / ZH
Switzerland

www.asp-ag.com



Made in Switzerland

About this Manual

Congratulations on your purchase of a TOP CLASS sinewave inverter. You are the owner of the finest engineered and highest quality sinewave inverter. We have dedicated our product's, our services and ourselves to the satisfaction of every customer.



This manual for installation and operation contains important information about this unit. Please familiarise yourself with all the information contained in these instructions before installing and operating this unit. This will help you to get acquainted properly with this unit and make full use of its advanced technical features under all operating conditions.

Should you encounter problems while installing or running this unit, please contact the dealer you purchased the unit from or a dealer authorised by ASP.

Improper assembly, installation and maintenance may impair the safety and function of this unit. For this reason make sure that you understand all the information in this manual before beginning the assembly and installation procedure.

Thank you again for choosing this product and to be a part of the ASP family!.

ASP Advanced Solar Products AG, CH-8637 Laupen/ZH

Limitation of liability

Since neither the observance of these instructions for installation and operation, nor the conditions and methods of installation, operation, utilisation and maintenance of the unit can be supervised by ASP, we don't assume any responsibility or liability for loss, damage or costs arising from using this unit or in any way connected with faulty installation, improper operation or incorrect utilisation and maintenance.

Furthermore we don't assume any responsibility for infringement of patent rights or violations of the rights of third parties arising from the utilisation of this unit.

We reserve the right to make product changes, change technical specifications or these instructions without prior notice.

Important: Please be informed that units without CE-declaration can only be used on your own liability in European countries. If you have an unit without CE please contact your local dealer.

WARNING! Unauthorized repairs and operation of this device for any use other than that for which it was intended will result in loss of warranty. If you have problems with the unit, ASP will provide you with the authorization necessary to return or repair a unit.

ASP Advanced Solar Products AG
Hauptstrasse 36B
CH-8637 Laupen/ZH
Switzerland

Phone. +41-(0)55-246 41 14
Fax: +41-(0)55-246 41 16
Internet: www.asp-ag.com
Email: aspinfo@bluewin.ch

Environmental protection



Recycling raw materials instead of waste disposal. This unit is built from valuable materials and is easy to recycle. The unit, accessories and packaging should be sorted for environment-friendly recycling. Please keep packaging for retransport the inverter later. To prevent damage during transport we have to use and bill you a new packaging if we receive the unit not with original packaging. Thank you.

Precautions

Warning! In this unit potential differences of up to 1000V occur during operation and can result in death or serious bodily injury. Use extreme caution while operating and always observe precautions as:

The unit must be connected by a professional electrician only.

Only specially trained maintenance and service personnel are permitted to test and repair this unit. This personnel further must be familiar with this manual and all domestic regulations.



No AC-generator or power supply is allowed to connect to this unit. Connecting mains power, AC-Generator or an other inverter to AC-output will damage the unit immediately. Excess voltage applied to the inputs and outputs may result in destruction of the unit.

Charging the battery with a dynamo while the inverter is connected to the battery, the inverter may be damaged. Please ask your dealer if you have any questions.

Take care of regulations for lightning protection.

The unit is tested by the manufacturer and it is not allowed to change anything! Without a written permission of ASP AG you will lose warranty if you repair the unit. Please refer to the warranty information.

Any work performed on this unit, its installation and electrical connection must be carried out in compliance with national electric codes and local regulations, which may deviate from those contained herein. Refer to responsible authorities for relevant information.

Operate the device only when all factory-supplied covers are available and in place.

Temperatures at the case of the device may be as high as 60 degrees C during operation. Obstruction of the ventilation of the unit may result in overheating and thus in failure of the unit. Always keep the unit and the ventilation slots clean. Do not cover up or place any item on ventilation holes or cooling components.

Please note the permissible ambient conditions for operating the unit.

Automatic restart of the unit may occur after fault clearance.

Please note that also under standby operation, 230V test voltage pulses are present at the inverter AC-output. The inverter is still ready to run. To be sure that the unit is completely switched off you have to switch the main circuit breaker in OFF-position or disconnect the battery.

Warning! Inbuilt, large electrolytic capacitors will hold DC-voltage for extended periods.



Do not use any measuring equipment damaged or defective.

Contact with energised parts can result in serious or fatal injury. Please note that, even under excessively light load or in stand by operation, high voltage can be present at the AC-output.

Maintenance and Spare parts

This unit is maintenance-free.

Proper functioning of the unit and electrical connections must be inspected at regular intervals - we recommend once a year - by trained electrical specialists. The routine inspection should include the entire electrical system.

Should malfunctions of the unit occur despite these inspections, the unit must be returned to the manufacturer for repair. Original spare parts are only available from ASP. ASP will provide you with the authorisation necessary to return a unit for repair. Before you call please

prepare you for the following questions: Type of unit, DC-voltage, manufacturing date, date of purchase, kind of fault, connected loads.

1. Unpacking the unit

Please check if the unit has no visible damage. If the unit is damaged you must inform your dealer within 3 days after receiving the unit. Store package in case you have to return the unit due to failure.

2. Function, technology

This inverter is designed to convert DC-battery voltage (direct voltage) to 230V AC (sinusoidal alternating voltage). Voltage controlled, the inverter provides a stabilised, crystal-accurate alternating 230V/50Hz voltage (different voltages and frequencies refer to the indication label). With a sine-wave inverter almost any type of electric consumer may be connected as for example energy saving lights, fluorescent tubes, computers, radio- and HIFI-equipment and other household appliances, freezers, pumps, motors etc.

Due to a high degree built-in safety, excellent dynamic response, a surge-proof and overload-proof output, it is very simple to operate a broad range of applications.

The "heart" of the inverter is a very powerful RISC-microprocessor of the latest generation. This microprocessor is responsible for the real time computing of the output sine-wave shape, for the process control of the output voltage, for the supervision of the battery (dynamic) and the inverter temperature.

The power stage features modern Power Mos-Fet transistors. These transistors are the key to the high partial-load efficiency and superb overload capability. The power transistors are protected by independent intelligent protection circuits. The inverter is further more protected against DC-over voltage (static) and short circuit on AC-output.

The battery input side is equipped with a thermal/magnetic circuit breaker to protect your system.

The superb toroidal transformer has very low magnetic losses, high efficiency and a very low RFI-radiation level. The transformer design provides a high efficiency over a wide operating range. No electrical connection between DC-input and AC-output due to the transformer. It complies with the following guidelines: IEC 742, EN60742, VDE 0551 TI, SEMLO 9742.

The whole control electronics are manufactured in SMD technology to ensure a high standard of quality and reliability. The RS232 interface is for internal use only and not accessible.

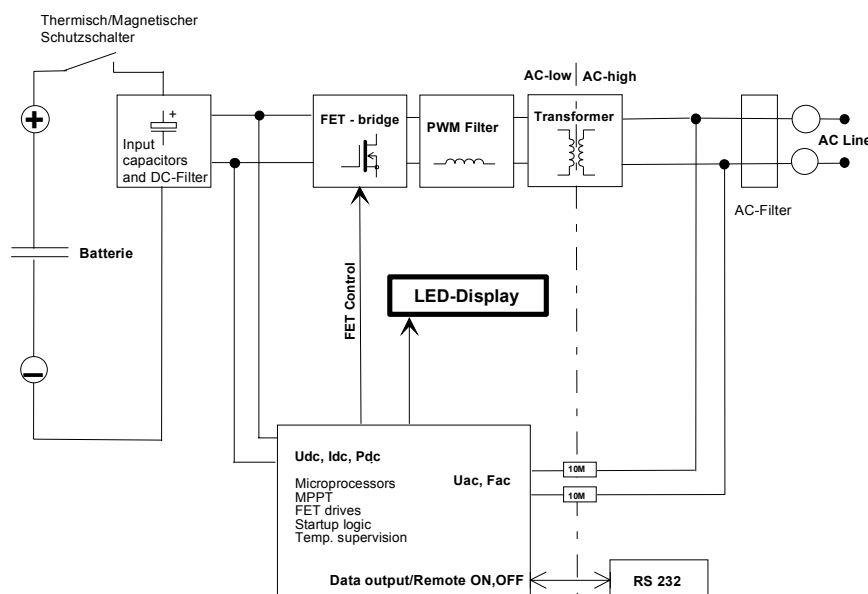

3. General information

Always check the power draw of your appliances. Electrical equipment as motors, pumps, compressors etc. need more power while starting up. Start up power draw can be much higher than P_{nom}. For this applications the inverter is able to supply up to 300% surge power for a short time. Be careful if you use pumps. Power declaration on pumps is usually not the electrical input power of the pump! The inverter switches off automatically if surge power is too high.

If ambient temperature is higher than 20 degrees C, P_{nom} and overload capability of the inverter will be reduced.

Due to reduced cooling capacity, P_{nom} of the inverter is reduced if operation altitude is above 900m ASL. Reduction of P_{nom} is approx. 1,5% per every additional 100m more altitude.

Example: If a 1000VA inverter is installed as high as 2500m ASL maximal P_{nom} will be at 780VA only! If you use more power, overheating and associated premature disconnection of the inverter must be anticipated.

If you use the inverter under above conditions we recommend to use a well over dimensioned inverter.

4. Installation

The selection of a safe location for installing the inverter depends on the following criteria:

- ◆ Check indication label for correct DC-Voltage and AC-Voltage.
- ◆ The inverter can be used in any position.
- ◆ Protection from unauthorized access in particular of children.
- ◆ Dry, dust free surroundings (max. 95% humidity, not condensing).
- ◆ Short distance between battery and inverter. Use a grounded metal pipe to reduce RFI emission and to prevent surroundings of fire. The inverter should not be mounted in the same room as the batteries are (gas of the batteries during charging).
- ◆ Adequate ventilation. Keep min. 10 cm distance to other objects (except mounting side)
- ◆ Battery capacity must be at least 200Ah. Using a smaller battery may reduce performance of the unit.
- ◆ If other DC-units are installed at the same battery, contact your dealer for more information.
- ◆ Protection of inverter and battery from the effects of water.
- ◆ Temperature range –25°C to +60 degrees C.
- ◆ Only specially trained maintenance and service personnel are permitted to test this unit. This personnel further must be familiar with this manual and all domestic regulations before installing this unit.

5. Connecting the inverter

The DC-circuit breaker must be turned to OFF-Position. **Note:** Inbuilt, large capacitors will hold DC-Voltage for extended periods. They still can have DC-Voltage even when the switch is in off position and the DC-Cables are disconnected from the battery!

First make AC-Connections. Connect your load with enclosed connector to the inverters AC-Output. An additional AC-Circuit breaker (size refer to datasheet) has to be installed. We recommend to install a earth leakage protector for protection of personnel. Please observe domestic regulations when making connections!

To connect the Battery to the inverter use a wire with minimum cross section of 25mm². An additional DC-breaker must be installed directly at the battery. Before connecting the cables to the battery make sure that the polarity is correct! Applying of wrong polarity may damage the inverter.

NOTE: Please exercise extreme care when connecting the unit to a battery. Otherwise the inverter or the battery could be damaged!

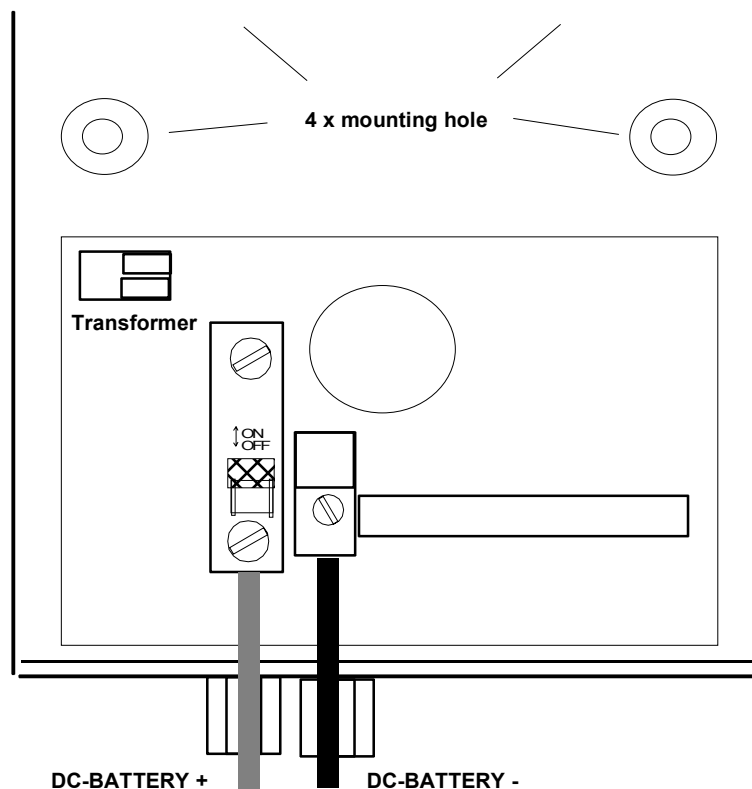

Take care of correct grounding of the inverter and your equipment that is connected to the inverter! We recommend to use an earth cable with minimum cross section of 10mm² to ground the inverter. This will help to protect your unit in case of lightning. Be sure to meet all regulations about lightning protection!

Check again to make sure all cables are securely connected. Switch on the DC-Circuit breaker. The inverter is now ready to operate.

6. Information for operation



Protect your inverter from rain. The unit is not designed to be used outdoor.

The DC-input breaker should be in „ON“-position all the time. In case of an error it will switch off automatically. If the inverter is switched off (by turning the potentiometer fully counter clockwise) it still needs app. 25mA from the battery. The inverter is electronically short circuit protected at the AC-Output.

DC input of the inverter is monitored for over voltage and under voltage. The upper limit is static. If DC-Voltage is too high the inverter will switch off. Automatic restart follows after DC-Voltage is in the normal range.

The lower limit is dynamic (cut off voltage is lower if a big load is in use). This allows an optimal use of the battery capacity and protects your battery during small load operation.
Important: If the inverter has switched off automatically it still needs very little power from the battery!

Important: Always before you switch on the circuit breaker you must switch off the load.

The fan is controlled by temperature and power needed. It is helping to reduce problems of overheating.

7. Status LED-display

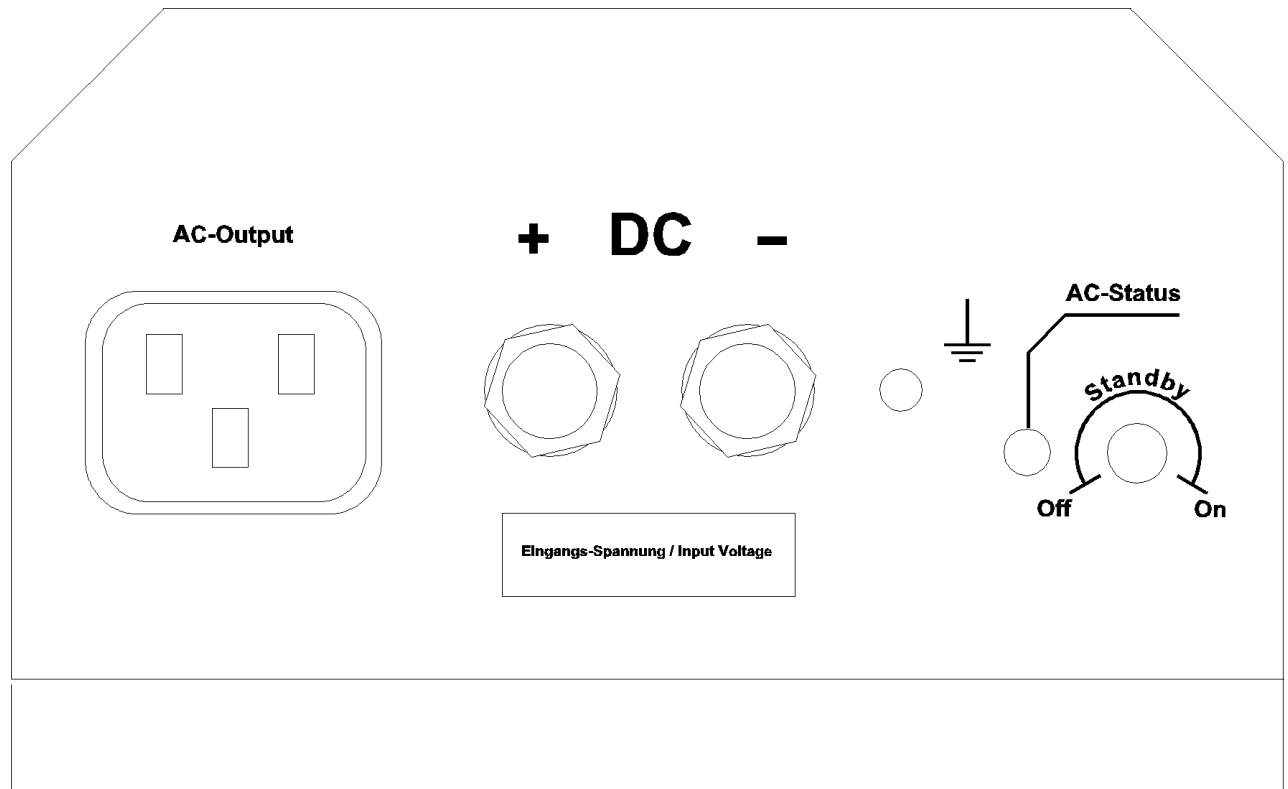

LOBAT: Battery voltage low. The inverter switches off automatically if DC-Voltage is out of range for more than 5 seconds (LED continuous red). **Warning!** The inverter restarts automatically if DC-Voltage is in permitted range.

OVERTEMP: Over-temperature. Overheating as a result of insufficient cooling or extended overload. The inverter switches off automatically after 5 seconds (LED flashing red). **Warning!** The inverter restarts automatically if temperature is in permitted range.

LED AC-Status: A red flashing LED means either lobat or overtemperature! During normal operation this LED emits a green light. Inverter ON - Output = 230V AC/50Hz (or as on compliance plate). During standby this LED blinks green. **Hint:** This LED blinks orange before the inverter switches to standby if the load is too small. Use this information to adjust the standby level to your load.

If AC-Output transcends tolerance (for ex. because of short circuit at the AC-Output) this LED emits a steady red light. **Warning!** The inverter restarts automatically after 60 seconds.

STDBY-ADJUST:

With this potentiometer placed next to the LED's you can adjust standby level in a range from app. 2 - 40W (app.100 steps). Turn the potentiometer completely counter clockwise: The inverter is always OFF (it still uses app.10mA from the battery). Turning the potentiometer clockwise: The standby level (for sleep mode) will increase from app. 2W to 40W. Fully clockwise – the inverter is ON all the times.

Important: Each time a fault occurs the inverter restarts automatically after 60 seconds or if the parameters (for example temperature) are back in normal conditions after a fault. Time before the unit starts again can be from a few seconds to a few hours! Always switch off the unit if you work at your system or electric consumer.

Additional information about standby/sleep mode

This specially designed standby circuit (energy saving circuit) recognizes automatically if power is needed at the AC-Output.

If no power is needed and after a delay of 10 seconds the unit switches into standby/sleep mode. In this operation mode power draw of the unit is less than 2W. Every 800ms the inverter checks the AC-Output by emulating a true sine-wave voltage. If power draw exceeds the adjusted sensitivity level the inverter switches on immediately. If no more power is needed the inverter switches back to standby mode after a delay of 10 seconds.

If you use a small, not compensated load it may occur that the inverter is switching on and off all the time. If this occurs you should compensate the load or switch an additional load to the AC-output.

Note: A lot of electrical equipment needs power even if they are switched off. Especially units as portable radios, TV- and video equipment, plug in power supplies etc. may have still such a high power draw that the inverter recognises a load and is not able to switch into standby/sleep mode. The sense level is adjustable on the potentiometer next to the LED's. You can adjust sensitivity level from app. 2W to 40W. Sensitivity level may slightly change depending on DC-Voltage of the battery and temperature of the inverter (app. +/- 1W).

Technical data's

TOP CLASS "DOMINO III"	TC05/12	TC07/24
Inverter		
Rated Voltage UDC _{IN}	12V	24V
Input Voltage Range	10.5 ... 16.0V DC	21.0 ... 32.0V DC
Dynamic Low Voltage Cut Off (depending on load)	10.5 ... 9.0V DC	21.0 ... 18.0V DC
Rated current IDC _{IN}	50A	35A
Current IDC _{IN} max.	160A	150A
Rated Power P ₁₀ (10 min at T _A =20°C)	675VA	1300VA
Rated Power P ₃₀ (30 min at T _A =20°C)	620VA	1100VA
Continuous Power P _D	550VA	710VA
Rated Output Voltage UAC _{OUT}	230V AC, ± 2% (short circuit proof)	
Output Frequency	50Hz, ± 0.5% (true sinewave)	
Rated Output Current IAC _{OUT}	2.1A	3.0A
Short Circuit Current IAC _K (max. 0.5s)	6A	8A
Allowable CosPhi	0.3 ... 1	
Efficiency Factor max.	93%	94%
Adjustable Standby Level (logarithmic)	2 ... 40W	
Consumption Standby/OFF	ca. 1.5W (Test impulse every 800ms) / 10mA	
Consumption 230V AC OK	5W	8W
Reset after Short Circuit	every 60s	
Reset after Overload	every 60s	
Reset after Overtemperature	automatically after reaching semiconductor temp. +45°C	
Reset after Battery failure	automatically after reaching UDC _{IN}	
General data		
Ambient Temperature range	-25°C ... +60°C (max. 95% rH, not condensing)	
DC- Breaker / fuse	63A	63A
Remote control ON / OFF	no	no
Status indication	LED	LED
Alarm contact (insulated Relay contact)	no	no
Toroidal Transformer (galvanically isolated)	IEC742, VDE0551	
Temperature and Load controlled fan	ON 55°C / OFF 45°C, P _D >80%	
RS-232 Interface	no	no
Dimensions (L x W x H)	275 x 155 x 96 mm	
IP Protection	IP20	
Standards	CE	
Included in delivery	connector for non-heating apparatus	
Weight	5.1 kg	6.8 kg
Warranty	2 years	

Technical changes reserved (02/2003)

8. Fault clearance

AC-Output LED is flashing red and green	refer to point 7. LED -Display
The unit is noisy and switches off	The load is too big, battery is too small
It is not possible to set DC-Circuit breaker in ON-Position	wrong polarity at DC-input, wrong installation
DC-Circuit breaker switches to OFF-Position	Overload operation for long time, reduce load
No function	Check wiring, check DC-Voltage

Before you call the help desk or your dealer please visit FAQ section on our home page: www.asp-ag.com Thank you!

9. Warranty (short form)

Dear Customer,

Thank you for buying this ASP product.

In the event that your ASP product needs guarantee service you should return it to the retailer from whom it was purchased.

We guarantee TOP CLASS appliances in accordance with statutory/country-specific regulations (proof of purchase by invoice or delivery note).

Damage attributable to normal wear and tear, overload or improper handling will be excluded from the guarantee.

In case of complaint please send the unit with the original packaging, undismantled to your dealer or an ASP service centre for inverters. Please be aware of the information we need to repair the unit as soon as possible (page 3, Maintenance and Spare parts).

ASP AG is not responsible for costs arising for transport of the unit or damage that occur if the unit is out of service. If you wish we will send you our complete documentation about our guarantee terms.

10. CE-Declaration of conformity

We declare under our sole responsibility that this product is in conformity with the following standards or standardisation documents: EN 50081-1 Generic 92, EN50082-1 Generic 92



A. Rüegg
ASP AG
Managing Director